

DSPH-1/DSPH-3

pH/Conductivity Meter

Operator's Manual



Additional products from



NEWPORT Electronics, Inc.

Counters	Rate Meters
Frequency Meters	Timers
PID Controllers	Totalizers
Clock/Timers	Strain Gauge
Printers	Meters
Process Meters	Voltmeters
On/Off	Multimeters
Controllers	Soldering Iron
Recorders	Testers
Relative	pH pens
Humidity	pH Controllers
Transmitters	pH Electrodes
Thermocouples	RTDs
Thermistors	Thermowells
Wire	Flow Sensors

For Immediate Assistance

In the U.S.A. and Canada: 1-800-NEWPORT[®]

In Mexico: (95) 800-NEWPORTSM

Or call your local NEWPORT Office

NEWPORTnetSM On-Line Service	Internet e-mail
http://www.newportUS.com	info@newportUS.com

It is the policy of NEWPORT to comply with all worldwide safety and EMC/EMI regulations that apply. NEWPORT is constantly pursuing certification of its products to the European New Approach Directives. NEWPORT will add the CE mark to every appropriate device upon certification.

The information contained in this document is believed to be correct but NEWPORT Electronics, Inc. accepts no liability for any errors it contains, and reserves the right to alter specifications without notice.

WARNING: These products are not designed for use in, and should not be used for, patient connected applications.

TRADEMARK NOTICE:

N, **N** **NEWPORT**, **NEWPORT**, newportUS.com[®], are trademarks of NEWPORT Electronics, Inc.



This device is marked with the international caution symbol. It is important to read the Setup Guide before installing or commissioning this device as it contains important information relating to safety and EMC.

<p>From the technical library of:</p> <p>_____</p>

Warranty/Disclaimer

NEWPORT Electronics, Inc. warrants this unit to be free of defects in materials and workmanship for a period of **one (1) year** from the date of purchase. In addition to NEWPORT's standard warranty period, NEWPORT Electronics will extend the warranty period for **one (1) additional year** if the warranty card enclosed with each instrument is returned to NEWPORT.

If the unit should malfunction, it must be returned to the factory for evaluation. NEWPORT's Customer Service Department will issue an Authorized Return (AR) number immediately upon phone or written request. Upon examination by NEWPORT, if the unit is found to be defective it will be repaired or replaced at no charge. NEWPORT's WARRANTY does not apply to defects resulting from any action of the purchaser, including but not limited to mishandling, improper interfacing, operation outside of design limits, improper repair, or unauthorized modification. This WARRANTY is VOID if the unit shows evidence of having been tampered with or shows evidence of being damaged as a result of excessive corrosion; or current, heat, moisture or vibration; improper specification; misapplication; misuse or other operating conditions outside of NEWPORT's control. Components which wear are not warranted, including but not limited to contact points, fuses, and triacs.

NEWPORT is pleased to offer suggestions on the use of its various products. However, NEWPORT neither assumes responsibility for any omissions or errors nor assumes liability for any damages that result from the use of its products in accordance with information provided by NEWPORT, either verbal or written. NEWPORT warrants only that the parts manufactured by it will be as specified and free of defects. NEWPORT MAKES NO OTHER WARRANTIES OR REPRESENTATIONS OF ANY KIND WHATSOEVER, EXPRESSED OR IMPLIED, EXCEPT THAT OF TITLE, AND ALL IMPLIED WARRANTIES INCLUDING ANY WARRANTY OF MERCHANTABILITY AND FITNESS FOR A PARTICULAR PURPOSE ARE HEREBY DISCLAIMED. LIMITATION OF LIABILITY: The remedies of purchaser set forth herein are exclusive and the total liability of NEWPORT with respect to this order, whether based on contract, warranty, negligence, indemnification, strict liability or otherwise, shall not exceed the purchase price of the component upon which liability is based. In no event shall NEWPORT be liable for consequential, incidental or special damages.

CONDITIONS: Equipment sold by NEWPORT is not intended to be used, nor shall it be used: (1) as a "Basic Component" under 10 CFR 21 (NRC), used in or with any nuclear installation or activity; or (2) in medical applications or used on humans. Should any Product(s) be used in or with any nuclear installation or activity, medical application, or used on humans, or misused in any way, NEWPORT assumes no responsibility as set forth in our basic WARRANTY / DISCLAIMER language, and additionally purchaser will indemnify NEWPORT and hold NEWPORT harmless from any liability or damage whatsoever arising out of the use of the Product(s) in such a manner.

Return Requests/Inquiries

Direct all warranty and repair requests/inquiries to the NEWPORT Customer Service Department. **BEFORE RETURNING ANY PRODUCT(S) TO NEWPORT, PURCHASER MUST OBTAIN AN AUTHORIZED RETURN (AR) NUMBER FROM NEWPORT'S CUSTOMER SERVICE DEPARTMENT (IN ORDER TO AVOID PROCESSING DELAYS).** The assigned AR number should then be marked on the outside of the return package and on any correspondence.

The purchaser is responsible for shipping charges, freight, insurance and proper packaging to prevent breakage in transit.

FOR **WARRANTY** RETURNS, please have the following information available **BEFORE** contacting NEWPORT:

1. P.O. number under which the product was **PURCHASED**,
2. Model and serial number of the product under warranty, and
3. Repair instructions and/or specific problems relative to the product.

FOR **NON-WARRANTY** REPAIRS, consult NEWPORT for current repair charges. Have the following information available **BEFORE** contacting NEWPORT:

1. P.O. number to cover the **COST** of the repair,
2. Model and serial number of product, and
3. Repair instructions and/or specific problems relative to the product.

NEWPORT's policy is to make running changes, not model changes, whenever an improvement is possible. This affords our customers the latest in technology and engineering.

NEWPORT is a registered trademark of NEWPORT Electronics, Inc.

© Copyright 2004 NEWPORT Electronics, Inc. All rights reserved. This document may not be copied, photocopied, reproduced, translated, or reduced to any electronic medium or machine-readable form, in whole or in part, without prior written consent of NEWPORT Electronics, Inc.

PATENT NOTICE: This product may be covered by one or more of the following patents: U.S. Pat. No. Des. 336,895; 5,274,577; 6,243,021 / CANADA 2052599; 2052600 / ITALY 1249456; 1250938 / FRANCE BREVET No. 91 12756 / SPAIN 2039150; 2048066 / UK PATENT No. GB2 249 837; GB2 248 954 / GERMANY DE 41 34398 C2. OTHER INTERNATIONAL PATENTS PENDING.

For immediate technical or application assistance please call:

1-800-6397678®
1-800-NEWPORT

Newport Electronics, Inc.

2229 South Yale Street • Santa Ana, CA • 92704 • U.S.A.

TEL: (714) 540-4914 • FAX: (203) 968-7311

Toll Free: 1-800-639-7678 • www.newportUS.com • e-mail: info@newportUS.com
ISO 9001 Certified

Newport Technologies, Inc.

976 Bergar • Laval (Quebec) • H7L 5A1 • Canada

TEL: (514) 335-3183 • FAX: (514) 856-6886

Toll Free: 1-800-639-7678 • www.newport.ca • e-mail: info@newport.ca

Newport Electronics, Ltd.

One Omega Drive • River Bend Technology Centre

Northbank, Irlam • Manchester M44 5BD • United Kingdom

Tel: +44 161 777 6611 • FAX: +44 161 777 6622

Toll Free: 0800 488 488 • www.newportuk.co.uk • e-mail: sales@newportuk.co.uk

Newport Electronics B.V.

Postbus 8034 • 1180 LA Amstelveen • The Netherlands

TEL: +31 20 3472121 • FAX: +31 20 6434643

Toll Free: 0800 0993344 • www.newport.nl • e-mail: info@newport.nl

Newport Electronics spol s.r.o.

Frystatska 184, 733 01 Karviná • Czech Republic

TEL: +420 59 6311899 • FAX: +420 59 6311114

Toll Free: 0800-1-66342 • www.newport.cz • e-mail: info@newport.cz

Newport Electronics GmbH

Daimlerstrasse 26 • D-75392 Deckenpfronn • Germany

TEL: 49 7056 9398-0 • FAX: 49 7056 9398-29

Toll Free: 0800 / 6397678 • www.newport.de • e-mail: sales@newport.de

Newport Electronique S.A.R.L.

11, rue Jacques Cartier • 78280 Guyancourt • France

TEL: +33 1 61 37 29 00 • FAX: +33 1 30 57 54 27

Toll Free: 0800 466 342 • www.newport.fr • e-mail: sales@newport.fr

Mexico and Latin America

FAX: 001 (203) 359-7807

En Español: 001 (203) 359-7803

NEWPORTnet™ On-Line Service www.newportUS.com
--

Internet e-mail info@newportUS.com
--

N® NEWPORT Electronics, Inc.

	Page
Section 1 Unpacking	2
Section 2 General Description	3
Section 3 Parts of the Meter	3
Section 4 Setting Up the Meter	4
Installing the Battery	4
Setting Up the Electrodes	5
Section 5 Calibrating the Meter	6
pH Mode	6
Conductivity Mode	7
Section 6 Operating Procedure	7
Section 7 pH Electrode Care	8
Section 8 pH Electrode Replacement	9
Section 9 Conductivity Electrode Care	10
Section 10 Conductivity Electrode Replacement	10
Section 11 Maintenance	11
Handling	11
Cleaning	11
Section 12 Specifications	11



Unpacking

Remove the Packing List and verify that you have received all equipment. If you have any questions about the shipment, please call the nearest Customer Service Department, listed in this manual.

When you receive the shipment, inspect the container and equipment for any signs of damage. Note any evidence of rough handling in transit. Immediately report any damage to the shipping agent.

**NOTE**

The carrier will not honor any claims unless all shipping material is saved for their examination. After examining and removing contents, save packing material and carton in the event reshipment is necessary.

Make sure the packing box contains the following:

- 1 soft carrying case
- 1 9V alkaline battery
- 1 wire brush
- 1 bottle of buffer solution (pH 7.00)
- 1 Operator's Manual

The carrying case contains the following:

- 1 small screwdriver
- 1 package of detergent powder (may be labelled "ALCONOX")
- 1 DSPH-1 or DSPH-3 Meter



General Description

The DSPH-1 and DSPH-3 meters feature both pH and conductivity measurements in one handheld instrument. The DSPH-1 measures pH from 0 to 14 and conductivity from 0 to 19,999 μmhos . The DSPH-3 extends the conductivity capability to 199,999 μmhos . While in use, the electrodes fold out and lock into a 90° or 180° position. When testing is completed, the electrodes fold back into the instrument case. Recessed switches control all functions and an easy-access panel reveals adjustments for pH calibration and slope, and zero and span for conductivity.

Parts of the Meter

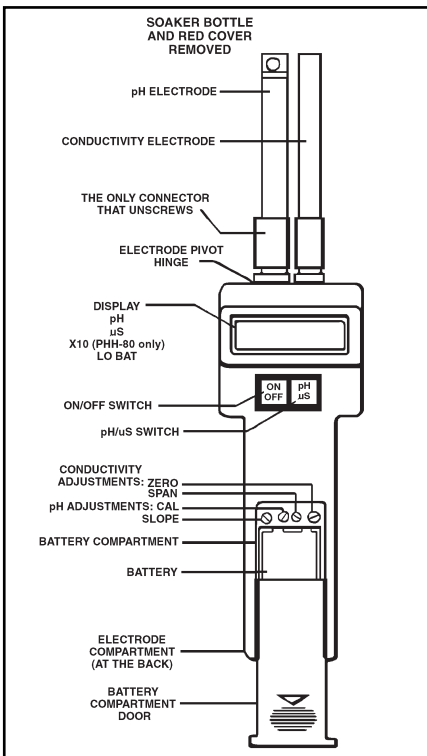

Figure 1. Parts of the Meter

Setting Up the Meter

Installing the Battery (Fig 2)

Carefully remove the meter from the carrying case making sure you don't lose the small screwdriver and detergent in a small plastic bag.

To install/change the battery, do the following:

1. Insert your thumb in the recessed area of the battery compartment door and pull it away from the display.
2. Snap the 9V alkaline battery into the battery clip.
3. Place the battery clip/battery assembly at the top of the battery compartment.
3. Replace the battery compartment door and snap into place.

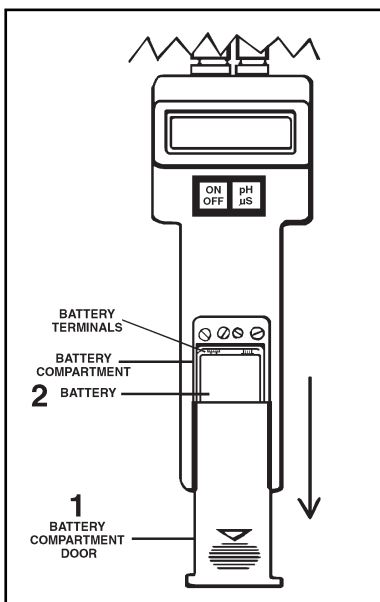

Figure 2. Installing the Battery



Setting Up the Electrodes

When you are ready to take your measurement(s), you must first remove the protective covers (caps) that are in place for storage. The pH electrode has the soaker bottle in place to protect the glass bulb inside the plastic sleeve, to protect from contamination and to prevent the electrode from drying out. The red cover (cap) covers the conductivity electrode, preventing fluid from entering the electrode when only pH is being measured and reduces the need for cleaning.

Setting Up the pH Electrode (Fig 3)

To remove the soaker bottle,

1. Extend the electrode pair to the 90° position.
2. Hold part of the electrode shafts and the white cap with one hand.
3. With the thumb and forefinger of the other hand loosen the bottle a couple of turns and slide the bottle and cap off carefully.

To put the bottle back on the electrode shaft, reverse the process stated above.

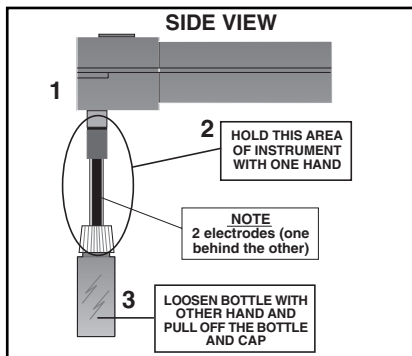

Figure 3. How to Loosen Bottle

Setting Up the Conductivity Electrode

To remove the cap, merely pull it off of the electrode shaft.



Calibrating the Meter

The meter is factory calibrated prior to shipping. However, since the electrode outputs change with age and condition it is important to calibrate with fresh pH buffers and known conductivity solutions prior to each use. Zero and span adjustments interact during calibration. Repeat calibration sequence at least two times or until readings stabilize. Rinse electrode in a separate distilled or deionized water container before dipping the electrode in pH7 solution to avoid contamination. Cross contamination of calibration standards will cause the appearance of “drift” in the instrument.

pH Mode

For best results, calibrate pH with a buffer that is within 3 pH units of the test sample.

1. Rinse the pH electrode in distilled or deionized water.
2. Insert in a fresh pH7 buffer solution.
3. Slide back the battery compartment door to the first stop, exposing the adjustment potentiometers (pots). Refer to Figure 1.
4. Adjust the CAL pot until the display reads 7.00.
5. Remove electrodes, rinse in distilled or deionized water and insert in a pH4 or pH10 buffer solution.
6. Adjust the SLOPE pot until the display reads the correct value.



Conductivity Mode

1. Rinse electrodes thoroughly by agitating in distilled or deionized water.
2. Wipe off conductivity electrode and allow it to dry.
3. When dry, conductivity should read "0" in air.
4. Adjust ZERO pot if reading is incorrect. If the conductivity electrode does not zero, it may indicate dried solids on the sensor. Clean with a mild detergent solution (such as Ivory).
5. Immerse electrode in a known conductivity solution. Choose a conductivity calibration solution that is near the range of the samples to be measured. Adjust SPAN pot to desired conductivity value.
6. Rinse electrodes and return to storage compartment.

Operating Procedure

The 9 volt battery should already be installed

1. Extend electrode pair to either the 90° or 180° measurement position.
2. Remove the electrode covers as described in "Setting Up the Electrodes" section.
3. Turn on the instrument by pressing the ON/OFF switch once.

"-1" and the unit of measure will momentarily appear and then a second number with the unit of measure is displayed. The display should show which parameter is being measured (for example, pH, μS (micro-siemens), or $\mu\text{S} \times 10$). Only the 200K range utilizes the $\times 10$ annunciator on the PHH-80. 20K and 2K are direct readings.



Overrange conductivity is indicated by "1" on the display.

4. Calibrate the meter before using the instrument. Refer to the previous section.
5. Immerse electrodes in solution to be measured. For proper operation, immerse electrodes to half their length.
6. Agitate electrodes briefly (to mix the sample) and observe the reading.
7. To change parameters, press the pH/ μ S switch one time. The range sequence on the PHH-80 is pH-200K-20K-2K.
8. Rinse the electrodes thoroughly and replace pH soaker bottle and conductivity cover before folding into storage compartment (at the back); fill the bottle with a small amount of pH4 buffer or pH7 buffer.
9. Remove the battery when the instrument is to be stored for a long period of time.

pH Electrode Care

pH Electrodes must be kept moist. The pH electrode was shipped stored in a soaker storage bottle. The storage solution contained in the bottle is a potassium chloride solution. Do not be alarmed if white crystals form at the end of the electrode. It is simply potassium chloride. Rinse with distilled water to dissolve the crystals before using the electrode.

For storage, place the electrode back in the soaker bottle. If the potassium chloride solution evaporates or is lost, simply use pH buffer 4.0 or pH buffer 7.0 supplied for storage. DO NOT use distilled or deionized water as this will drastically reduce the electrode lifespan.



If the pH electrode should dry out, soak the electrode up to 2 hours in pH buffer 4.0 solution. If the electrode is left dry from an extended period of time, permanent damage will result.

pH Electrode Replacement

The pH electrode can be replaced with the replacement electrode (part number PHE-8200). Please contact the nearest Customer Service Department, as listed in this manual.

To remove the electrode, simply unscrew it clockwise from the electrode pivot hinge on the meter. You will hear a pop; that's OK. Refer to Figure 4.

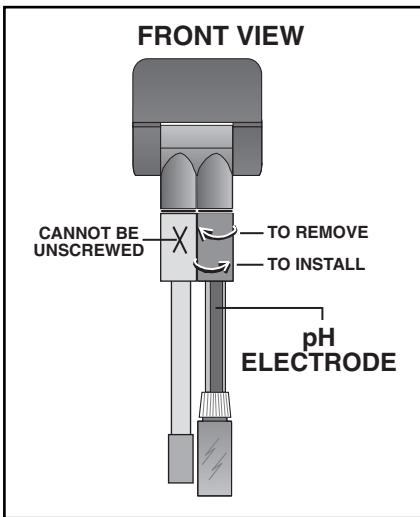

Figure 4. How to Unscrew the pH Electrode

To install a new electrode, attach the connector ends and screw counter-clockwise or to the right until you have a good connection.



Conductivity Electrode Care

The conductivity electrode needs to be kept clean and free of deposits and other types of build-up. Use the detergent powder supplied in the plastic bag for cleaning the electrode.

1. Mix a convenient amount of cleaning solution using the detergent powder. Use a mixing ratio that is 30 grams of powder to 4 liters of water (the bag contains 30 grams).
2. Dip the brush into the cleaning solution.
3. Insert the brush into the conductivity electrode approximately 1½" taking care to clean both conductance rings. One ring is located at the bottom of the electrode and the other is located approximately 1" up from the bottom, above the blue collar.
4. Twist the brush and scrub up and down for 20 to 30 seconds.
5. Rinse the electrode thoroughly in distilled or deionized water.
6. Clean the brush with tap water and rinse it with distilled or deionized water after using.

Conductivity Electrode Replacement

THE CONDUCTIVITY ELECTRODE CANNOT BE UNSCREWED (THIS IS THE ELECTRODE WITH A SMALL HOLE IN THE BLUE CONNECTOR HOUSING). The conductivity electrode is field replaceable by qualified technicians only. The part number of the conductivity electrode is CDE-8200. Contact the nearest Customer Service Department for instructions on how to replace the electrode.



Maintenance

Handling

DO NOT lay instrument on display with wet electrode since the liquid may enter the instrument case through the base of the electrode creating a short or circuit board damage. Shake the instrument vigorously after each use to remove ALL water from the side of the pH electrode and inside of the conductivity electrode.

Cleaning

Both electrodes are equipped with protective caps. The bottle on the pH electrode protects the glass bulb inside the plastic sleeve, protects it from contamination and prevents it from drying out. The red cap on the conductivity electrode prevents fluid from entering the electrode when only pH is being measured and reduces the need for cleaning. Clean both electrodes before storing to prevent build-up of sediment and to assure long life.

Specifications

pH

Range:	0 to 14
Accuracy:	±0.01 pH
Temperature Compensation:	Automatic 0° to 70°C

Conductivity

Range	
DSPH-1:	0 to 19,999 µmhos
DSPH-3:	0 to 1,999; 0 to 19,999; 0 to 199,999 µmhos
Resolution:	10 ppm or 10 µmhos
Accuracy:	±2% of span
Temperature Compensation:	Automatic 0° to 50°C
Power:	9V alkaline battery
Dimensions:	6¼" x 1¼" x 2¼" (158.75 x 31.75 x 57.15 mm)
Weight:	8.5 oz (241 g)



pH/Conductivity Meter

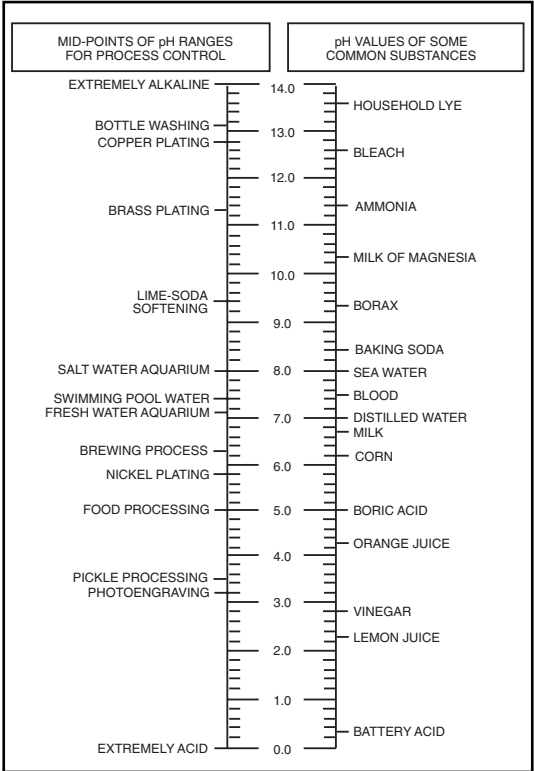

Figure 5. pH Values Common Industrial and Household products