

TX94A



RTD ULTRA-MINI TEMPERATURE TRANSMITTER

Operator's Manual



NEWPORT Electronics, Inc.

<http://www.newportUS.com/manuals>

Additional products from
N[®] NEWPORT Electronics, Inc.

Counters	Rate Meters
Frequency Meters	Timers
PID Controllers	Totalizers
Clock/Timers	Strain Gauge Meters
Printers	Voltmeters
Process Meters	Multimeters
On/Off Controllers	Soldering Iron Testers
Recorders	pH pens
Relative Humidity	pH Controllers
Transmitters	pH Electrodes
Thermocouples	RTDs
Thermistors	Thermowells
Wire	Flow Sensors

For Immediate Assistance
In the U.S.A. and Canada: 1-800-NEWPORT[®]
In Mexico: (95) 800-NEWPORTSM
Or call your local NEWPORT Office.

NEWPORTnetSM On-Line Service
<http://www.newportUS.com>

Internet e-mail
info@newportUS.com

It is the policy of NEWPORT to comply with all worldwide safety and EMC/EMI regulations that apply. NEWPORT is constantly pursuing certification of its products to the European New Approach Directives. NEWPORT will add the CE mark to every appropriate device upon certification.

The information contained in this document is believed to be correct but NEWPORT Electronics, Inc. accepts no liability for any errors it contains, and reserves the right to alter specifications without notice.

WARNING: These products are not designed for use in, and should not be used for, patient connected applications.

TRADEMARK NOTICE: **N**, **N[®] NEWPORT[®]**, **NEWPORT[®]** and **newportUS.com** are trademarks of NEWPORT Electronics, Inc.

PATENT NOTICE: The "Meter Case Bezel Design" is a trademark of NEWPORT Electronics, Inc., registered in the U.S.. This product is covered by one or more of the following patents: U.S. Pat. No. Des. 336,895; 5,274,577 / CANADA 2052599; 2052600 / ITALY 1249456; 1250938 / FRANCE BREVET No. 91 12756 / SPAIN 2039150; 2048066 / UK PATENT No. GB2 249 837; GB2 248 954 / GERMANY DE 41 34398 C2. OTHER INTERNATIONAL PATENTS PENDING.

 This device is marked with the international caution symbol. It is important to read the Setup Guide before installing or commissioning this device as it contains important information relating to safety and EMC.

TABLE OF CONTENTS

Section 1	Getting Started	
	1.1 Unpacking	1
	1.2 Safety and EMC Considerations	1
	1.3 General Description	2
	1.4 Features	2
	1.5 Models Available	3
Section 2	Installation	
	2.1 Mounting	4
	2.2 Wiring	5
Section 3	Calibration Instructions	
	3.1 Equipment Required	6
	3.2 Set-up of Equipment.	6
	3.3 Calibration Procedures.	7
Section 4	Troubleshooting Guide	8
Section 5	Specifications	9

FIGURES & TABLES

Figure 1-1	RTD Transmitter	2
Figure 2-1	Assembly inside a Protection Head	4
Figure 2-2	Wiring Diagram for RTD Transmitter	5
Figure 3-1	Transmitter Calibration Set-Up	7
Figure 5-1	Dimensions	9
Table 1-1	Range Code	3
Table 1-2	Model Numbers	3
Table 3-1	Calibration Values	7

1.1 Unpacking

Remove the packing list and verify that you have received all equipment. If you have any questions, contact the nearest Customer Service Department, as listed on the cover of this manual.

Upon receipt of shipment, inspect the container and equipment for any signs of damage. Note any evidence of rough handling in transit. Immediately report any damage to the shipping agent.

Note

Note: The carrier will not honor any claims unless all shipping material is saved for their examination. After examining and removing contents, save packing materials and carton in the event reshipment is necessary.

1.2 Safety and EMC Considerations

This instrument is a Class III device (8 to 35 Vdc).

Always use a power supply, which complies with EN 60950 safety standard.

- Do not expose the transmitter to rain or condensing moisture.
- Do not operate the transmitter in flammable or explosive atmosphere.
- As with any electronic instrument, you may encounter high voltage exposure when installing, calibrating or removing parts of the transmitter.

EMC Considerations

- Whenever EMC is an issue, always use shielded cables.
- Never run signal and power wires in the same conduit.
- Use signal wire connections with twisted-pair cables.
- Install Ferrite Bead(s) on signal wires close to the instrument if EMC problems persist.

Failure to follow all instructions and warnings may result in injury!

1.3 General Description

The Two-Wire RTD Transmitter will produce a standard 4-20mA output signal proportional to that produced by its RTD input temperature sensor. Transmission of the proportional current output may be accomplished by using inexpensive copper wire. The RTD transmitter accepts two-wire or three-wire ohm platinum RTD sensors (PT100, $\alpha = 0.00385$).

1.3 General Description

The transmitter is normally powered by an unregulated power supply as shown in **Figure 1-1**. The proportionally-transmitted signal begins at 4mA, at the low end of its temperature range, and increases to 20mA, at the high end of its temperature range. (There are various temperature ranges available for the transmitter. To order, refer to **Section 1.5** for correct Model Numbers and Range Codes.)

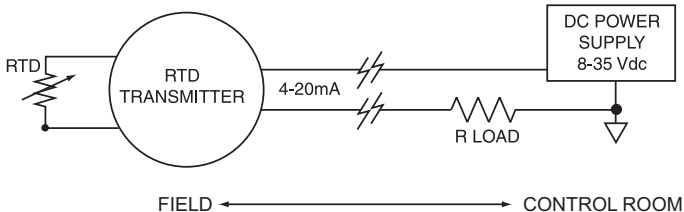

Figure 1-1 RTD Transmitter

The transmitter works with 2 or 3-wire RTDs and provides an output current of 4-20mA proportional to the RTD Sensor.

When the transmitter is mounted inside a protection head, (see **Figure 2-1**), two copper wires now carry the temperature signal and dc voltage to operate the transmitter, thereby reducing possible noise pick-up errors.

The transmitter does NOT provide isolation between its input and the 4-20 mA output. Note, however, that the RTD element is electrically insulated.

1.4 Features

- +/-0.1% full-scale accuracy (with respect to the RTD input resistance)
- 4-20 mA output
- Upscale break protection
- Low Cost

1.5 Models Available

Table 1-1 Range Code

INPUT TYPES

RANGE	RTD
-40 to 120 F (-40 to 49 C)	1
0 to 200 F (-18 to 93 C)	2
0 to 300 F (-18 to 149 C)	3
0 to 500 F (-18 to 260 C)	4
0 to 750 F (-18 to 399 C)	5
0 to 1000 F (-18 to 538 C)	6

Table 1-2 Model Numbers

Model Number	Description
TX94A-(*)	RTD Transmitter (100 ohm, Pt, alpha=0.00385)

*Insert range code from **Table 1-1**

2.1 Mounting

The transmitter may be:

1. surface mounted
2. mounted inside a protection head (shown in **Figure 2-1**)

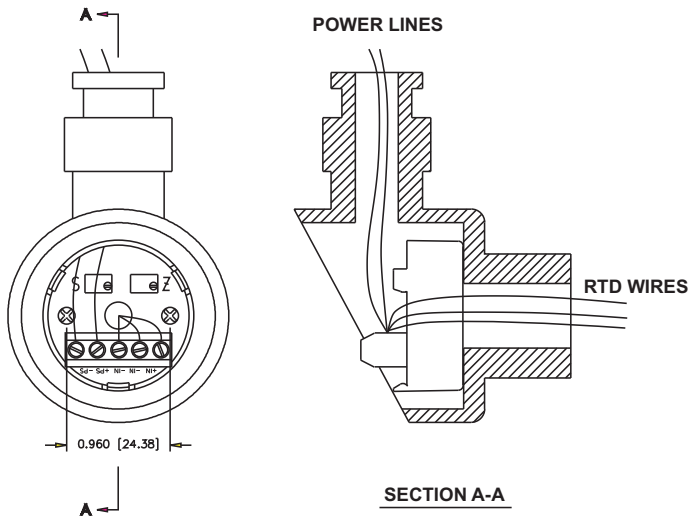

Figure 2-1 Assembly of the Transmitter inside an PR-14 Protection Head

2.2 Wiring

Refer to **Figure 2-2**

1. Connect a dc power supply in series with the load to the (+PS) and (-PS) power terminals. Note that the load (usually a monitoring instrument) may be connected to either the (+) or (-) power lead.
2. Connect the RTD element to the (+IN) and (-IN) input terminals.

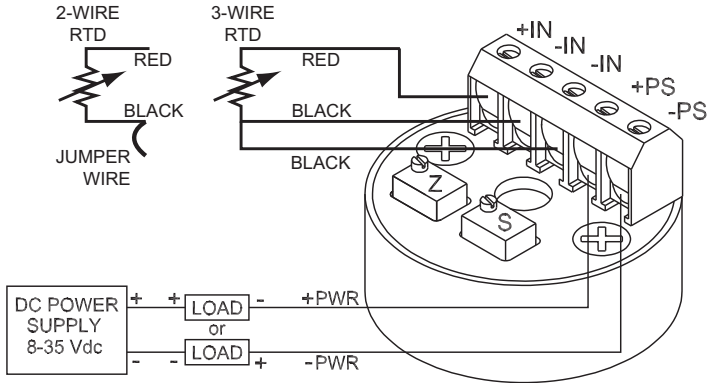

Figure 2-2 Wiring Diagram for RTD Transmitter

3.1 Equipment Required

- Precision Decade Resistance Box, with 0.01 ohm resolution and ± 0.02 ohm accuracy
or
- Precision RTD Simulator, such as OMEGA CL511 Precision Calibrator
- Precision DMM capable of measuring mA, within 0.001 mA resolution and ± 0.002 mA accuracy

3.2 Calibration Procedures

Connect the calibration equipment according to **Figure 3-1**. Standard copper test leads are used with RTD instrumentation.

To check or adjust the calibration:

1. Locate the Z (zero) and S (span) potentiometers.
2. Select, from **Table 3-1**, the correct ohmic values for the Z (zero) and S (span) adjustments that correspond to the model number.
For example, for Model TX94A-2, the Z value is 92.95 ohms, and the S value is 135.84 ohms.

If a Thermocouple/RTD Simulator is used, such as the Model CL511 Precision Calibrator, select the Temperature Input Z (zero) and S (span) values.

3. Set the Decade Box to the selected Z (zero) ohmic value. Adjust the Z potentiometer to read 4.000 mA on the monitoring instrument.
4. Set the Decade Box to the selected S (span) ohmic value. Adjust the S potentiometer to read 20.000 mA on the monitoring instrument.
5. Repeat steps 3 and 4, as required, until the readings are exactly 4.000 mA and 20.000 mA. This procedure is necessary since there is interaction between the two potentiometers.

3.2 Calibration Procedures (continued)

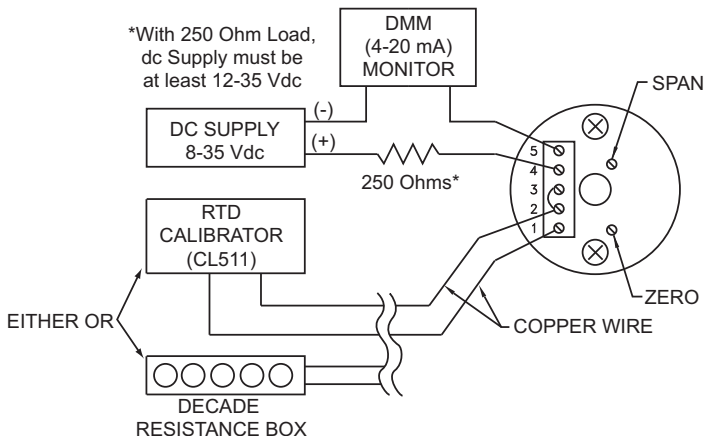

Figure 3-1 Transmitter Calibration Set-Up

Table 3-1. Calibration Values

Temperature Input Range Zero/Span	Model TX94A	Resistance Input (Ohms) Alpha=0.00385 Zero/Span
-40/120°F	-1	84.27 / 119.01
0/200°F	-2	92.95 / 135.84
0/300°F	-3	92.95 / 156.94
0/500°F	-4	92.95 / 197.69
0/750°F	-5	92.95 / 246.69
0/1000°F	-6	92.95 / 293.46

4.1 Troubleshooting Guide

Malfunction or incorrect operation may be caused by:

1. Incorrect Readings:

Check for improper wiring using **Figure 2-2** as a guide.

2. Loose or broken wires:

Check each terminal connection for tightness. Move each wire back and forth and note any changes in operation.

3. Too high a load resistance in the output current loop or too low a current rating on the power supply:

a) Measure the total resistance of each device (excluding the transmitter and power supply) in the 20 mA loop, including the resistance of the lead wires.

b) Calculate maximum allowable loop resistance using the formula: Loop Resistance (maximum) = $\frac{V_{\text{supply}} - 8 \text{ V}}{0.020\text{A}}$

0.020A

For example, a 24V power supply would give a maximum loop resistance of: $16 \text{ V}/0.020\text{A} = 800 \text{ ohms}$.

c) Make sure the power supply is rated for at least 28 mA times the number of transmitters being powered. For example, if the supply is powering five transmitters, the supply should be rated for at least 140mA.

5.1 Specifications

General

Size:

1.40" dia. x 0.93" high
(includes terminal strip)

Weight:

0.53 oz (15g);
0.83 oz (25g) if potted

Ambient Temperature:

-13°F to 185°F
(-25°C to 85°C)

Storage Temperature

-85°F to 257°F
(-65°C to 125°C)

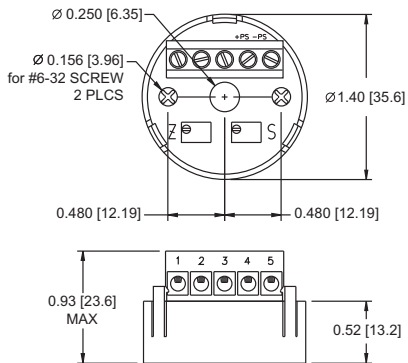

Figure 5-1 Dimensions

Zero/Span Adj Range:

±25%

Power Supply Voltage

Operating Range:

+8 Vdc to +35 Vdc, 28 mA max
required per transmitter

Accuracy:

±0.1% of full scale (includes effects of
hysteresis, and repeatability)

Frequency Response:

3dB@ 3Hz

Thermal Zero Shift:

<0.01% / °F of span (span >10 mV)
<0.02% / °F of span (4-10 mV span)

Thermal Span Shift:

<0.01% / °F of span

5.1 Specifications (continued)

Output

Current Output Span:	4-20 mA dc
Current Output Limits:	3 to 28 mA, typical
Max Loop Resistance:	$(V_{\text{supply}} - 8V) / 0.020A = \text{ohms}$
Load Resistance Effect:	0.01% of span per 300 ohms change
Power Supply Effect:	0.002% of output span per volt

Input

Sensor:	2 or 3-wire RTD
Max. Bridge Current:	2 mA

Warranty/Disclaimer

NEWPORT Electronics, Inc. warrants this unit to be free of defects in materials and workmanship for a period of one (1) year from the date of purchase. In addition to NEWPORT's standard warranty period, NEWPORT Electronics will extend the warranty period for one (1) additional year if the warranty card enclosed with each instrument is returned to NEWPORT.

If the unit should malfunction, it must be returned to the factory for evaluation. NEWPORT's Customer Service Department will issue an Authorized Return (AR) number immediately upon phone or written request. Upon examination by NEWPORT, if the unit is found to be defective it will be repaired or replaced at no charge. NEWPORT's WARRANTY does not apply to defects resulting from any action of the purchaser, including but not limited to mishandling, improper interfacing, operation outside of design limits, improper repair, or unauthorized modification. This WARRANTY is VOID if the unit shows evidence of having been tampered with or shows evidence of being damaged as a result of excessive corrosion; or current, heat, moisture or vibration; improper specification; misapplication; misuse or other operating conditions outside of NEWPORT's control. Components which wear are not warranted, including but not limited to contact points, fuses, and triacs.

NEWPORT is pleased to offer suggestions on the use of its various products. However, NEWPORT neither assumes responsibility for any omissions or errors nor assumes liability for any damages that result from the use of its products in accordance with information provided by NEWPORT, either verbal or written. NEWPORT warrants only that the parts manufactured by it will be as specified and free of defects. NEWPORT MAKES NO OTHER WARRANTIES OR REPRESENTATIONS OF ANY KIND WHATSOEVER, EXPRESSED OR IMPLIED, EXCEPT THAT OF TITLE, AND ALL IMPLIED WARRANTIES INCLUDING ANY WARRANTY OF MERCHANTABILITY AND FITNESS FOR A PARTICULAR PURPOSE ARE HEREBY DISCLAIMED. LIMITATION OF LIABILITY: The remedies of purchaser set forth herein are exclusive and the total liability of NEWPORT with respect to this order, whether based on contract, warranty, negligence, indemnification, strict liability or otherwise, shall not exceed the purchase price of the component upon which liability is based. In no event shall NEWPORT be liable for consequential, incidental or special damages.

CONDITIONS: Equipment sold by NEWPORT is not intended to be used, nor shall it be used: (1) as a "Basic Component" under 10 CFR 21 (NRC), used in or with any nuclear installation or activity; or (2) in medical applications or used on humans. Should any Product(s) be used in or with any nuclear installation or activity, medical application, or used on humans, or misused in any way, NEWPORT assumes no responsibility as set forth in our basic WARRANTY / DISCLAIMER language, and additionally purchaser will indemnify NEWPORT and hold NEWPORT harmless from any liability or damage whatsoever arising out of the use of the Product(s) in such a manner.

Return Requests/Inquiries

Direct all warranty and repair requests/inquiries to the NEWPORT Customer Service Department. BEFORE RETURNING ANY PRODUCT(S) TO NEWPORT, PURCHASER MUST OBTAIN AN AUTHORIZED RETURN (AR) NUMBER FROM NEWPORT'S CUSTOMER SERVICE DEPARTMENT (IN ORDER TO AVOID PROCESSING DELAYS). The assigned AR number should then be marked on the outside of the return package and on any correspondence.

The purchaser is responsible for shipping charges, freight, insurance and proper packaging to prevent breakage in transit.

FOR **WARRANTY** RETURNS, please have the following information available BEFORE contacting NEWPORT:

1. P.O. number under which the product was PURCHASED.
2. Model and serial number of the product under warranty, and
3. Repair instructions and/or specific problems relative to the product.

FOR **NON-WARRANTY** REPAIRS, consult NEWPORT for current repair charges. Have the following information available BEFORE contacting NEWPORT:

1. P.O. number to cover the COST of the repair,
2. Model and serial number of product, and
3. Repair instructions and/or specific problems relative to the product.

NEWPORT's policy is to make running changes, not model changes, whenever an improvement is possible. This affords our customers the latest in technology and engineering.

NEWPORT is a registered trademark of NEWPORT Electronics, Inc.

© Copyright 2005 NEWPORT Electronics, Inc. All rights reserved. This document may not be copied, photocopied, reproduced, translated, or reduced to any electronic medium or machine-readable form, in whole or in part, without prior written consent of NEWPORT Electronics, Inc.

For immediate technical or application assistance please call:

1-800-6397678®
1-800-NEWPORT

Newport Electronics, Inc.

2229 South Yale Street • Santa Ana, CA • 92704 • U.S.A.

TEL: (714) 540-4914 • FAX: (203) 968-7311

Toll Free: 1-800-639-7678 • www.newportUS.com • e-mail: info@newportUS.com

ISO 9001 Certified

Newport Technologies, Inc.

976 Bergar • Laval (Quebec) • H7L 5A1 • Canada

TEL: (514) 335-3183 • FAX: (514) 856-6886

Toll Free: 1-800-639-7678 • www.newport.ca • e-mail: info@newport.ca

Newport Electronics, Ltd.

One Omega Drive • River Bend Technology Centre

Northbank, Irlam • Manchester M44 5BD • United Kingdom

Tel: +44 161 777 6611 • FAX: +44 161 777 6622

Toll Free: 0800 488 488 • www.newportuk.co.uk • e-mail: sales@newportuk.co.uk

Newport Electronics B.V. - Benelux

TEL: +31 20 3472121 • FAX: +31 20 6434643

Toll Free: 0800 0993344 • www.newport.nl • e-mail: info@newport.nl

Newport Electronics spol s.r.o.

Frystatska 184, 733 01 Karviná • Czech Republic

TEL: +420 59 6311899 • FAX: +420 59 6311114

Toll Free: 0800-1-66342 • www.newport.cz • e-mail: info@newport.cz

Newport Electronics GmbH

Daimlerstrasse 26 • D-75392 Deckenpfronn • Germany

TEL: 49 7056 9398-0 • FAX: 49 7056 9398-29

Toll Free: 0800 / 6397678 • www.newport.de • e-mail: sales@newport.de

Newport Electronique S.A.R.L. - France

TEL: +33 1 61 37 29 00 • FAX: +33 1 30 57 54 27

Toll Free: 0800 466 342 • www.newport.fr • e-mail: sales@newport.fr

Mexico and Latin America

FAX: 001 (203) 359-7807

TEL En Español: 001 (203) 359-7803

NEWPORTnet™ On-Line Service www.newportUS.com
--

Internet e-mail info@newportUS.com
--



NEWPORT Electronics, Inc.